

GENESIS OR DYNA~TROL

This drawing shows how to control an external ventilation system with a Genesis or DynaTrol control.

The SAFETY output on the control turns on when a program is firing and can actuate a 12-volt relay.

The relay can be mounted inside or outside the kiln control panel.

Use the Normally Open contacts of the 12-volt, 25-amp relay to turn on and off the external ventilation system. Be sure that whatever relay you use is rated for the amperage load and voltage of your ventilation system.

Do not bring 480 volts into the kiln control panel.

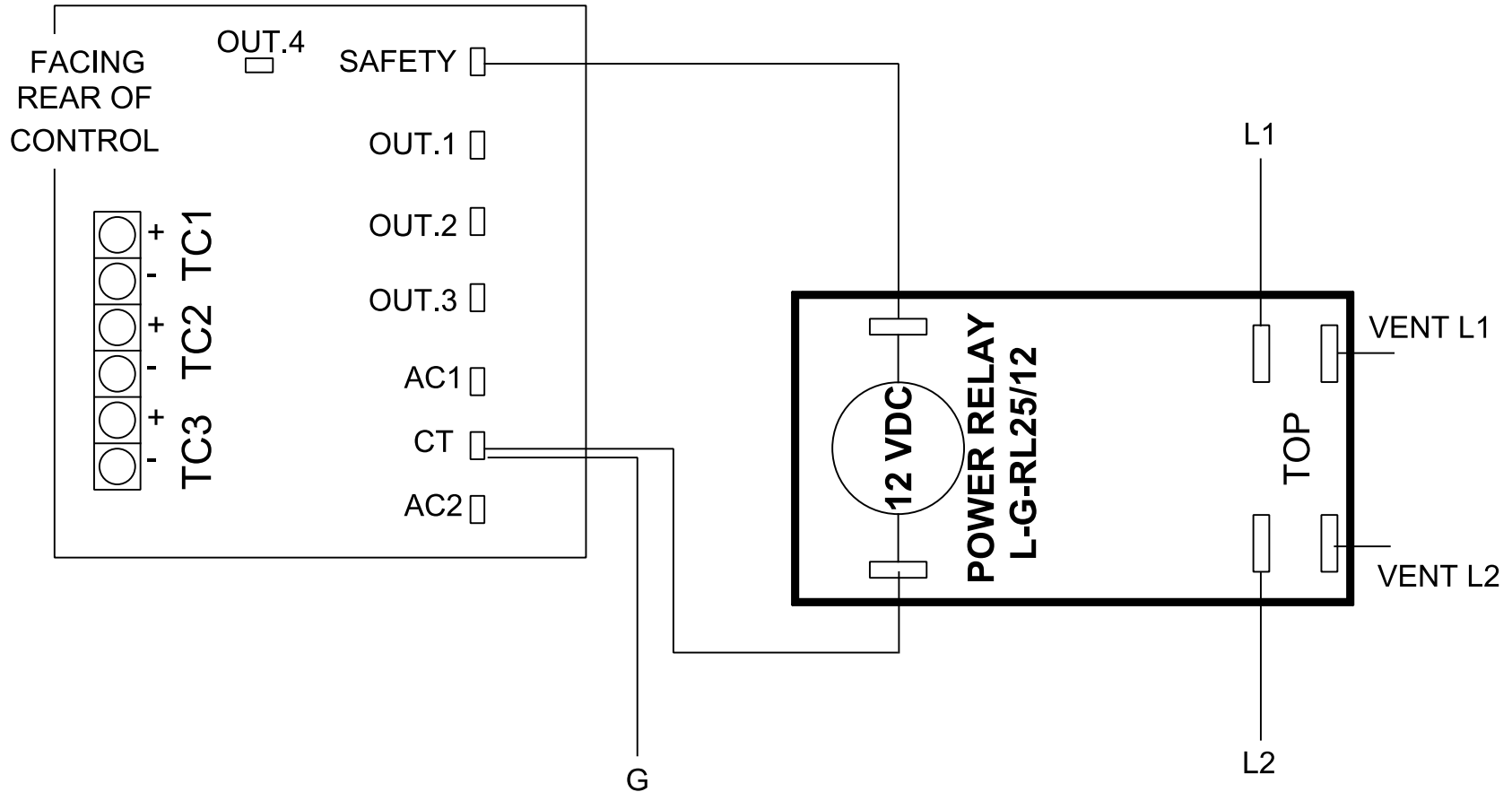

REV. #	DATE	REVISION DESCRIPTION