

Basic Electrical Safety

- **Always turn off the power:** Before starting any work on an electrical circuit, make sure to turn off the power supply to that circuit. This can be done by switching off the circuit breaker or unplugging the device. Use a voltage tester or multimeter to ensure that there is no electrical current flowing **before** starting work.
- **Wear protective gear:** When working with electricity, it's important to wear the right protective gear, such as rubber gloves, and safety glasses. This can help to protect you from electrical shock and other hazards.
- **Work with a partner:** Work with a partner who can assist you and watch out for your safety.
- **Stay Dry:** Make sure the area is dry. **Water conducts electricity.**
- **The higher the voltage the more dangerous** (for instance, only a trained electrician should go near 480 volts).

Working with a Multimeter to test Ohms

- **FIRST:** See our website for videos and directions: hotkilns.com/test-ohms
- Sometimes the only way to troubleshoot a kiln problem is to test circuits with live electricity using a multimeter. The design of L&L control panels makes this safer because you **do not need to hold the control panel and you can keep both hands free.**
- **Measuring Ohms:** The measurement of ohms (resistance in elements) can and should be done with the kiln disconnected from the power source. Unplug or turn off power at the circuit breaker and lock out if you are in an industrial or commercial setting.
- **Read the manual:** If you have not used the meter before read the manual.
- **Choose the correct settings:** Select the appropriate settings on the multi-meter for the measurement you will be taking. This may include selecting the measurement type, voltage range, or resistance range.
- **Connect the leads:** Connect the multi-meter leads to the circuit or device being tested, being careful to avoid touching the leads or metal parts of the device with your hands.
- **Read the display:** Once the leads are connected, read the display on the multi-meter carefully. Ensure that the measurement is within the range of the multi-meter and that the device is functioning properly.

Basic Electricity

- **Volts** represent the force or pressure pushing electricity through the wires, relays, and elements in the circuit. Voltage is typically predetermined by your electrical supplier and

varies from place to place.

Household voltage is typically 240 volts (with 120 volts from a hot leg to Neutral) but can be 208 volts in some USA houses and can be anywhere from 200 to 240 volts around the world (or higher).

- **Amps (Current)** measure the volume of electricity flowing through the circuit. Current is limited by the size of wires and fuse box in your house or business (often 200 amps in a house).
- **Ohms** measure the resistance to flow in the circuit. The resistive material in kiln elements allows heat to build up for the kiln to get hot.
- **Watts** measure the power, which determines how quickly a kiln can heat up and the maximum temperature it can reach. The more watts a kiln has, the faster it can heat up and reach higher temperatures. Larger kilns need more watts than smaller ones.

The Water Analogy

- Electricity is often compared to water flow and pressure for easier understanding.
- The supply of electricity to a kiln is like a reservoir of water - it is not used until the tap is turned on (which is like a switch).
- **Amps** measure the **volume** of electricity flowing through a wire in one second. That would be like the volume of water flowing through a pipe and any moment.
- **Volts** are the electrical **pressure** that forces electricity through the wires. It is similar to water pressure. For instance, if you have low water pressure in your house, the flow of water at the faucet, regardless of the size of the pipes, will be slow.
- **Ohms** measure the **resistance** to electricity flow, and the higher the resistance, the higher the number of ohms. A heating element can be explained in terms of water flow using the analogy of a narrow pipe. Imagine a pipe that is very narrow and has a constant flow of water passing through it. As the water flows through the narrow pipe, it encounters resistance, which causes friction between the water molecules and the pipe walls. This friction generates heat, which can be thought of as the equivalent of the heating element in an electrical circuit.
- **Watts** measure the **work** done by electricity and are calculated by multiplying the values of volts and amps. Imagine filling a bathtub. The amount of what going into the tub is like the number of watts going into a kiln. Imagine a bathtub with made of thick almost impervious sponge and you can imagine a kiln where the insulation absorbs some of the power (watts) and leaks some out as well.

Ohm's Law

Ohm's law is the basic mathematical way that all these various terms are related.

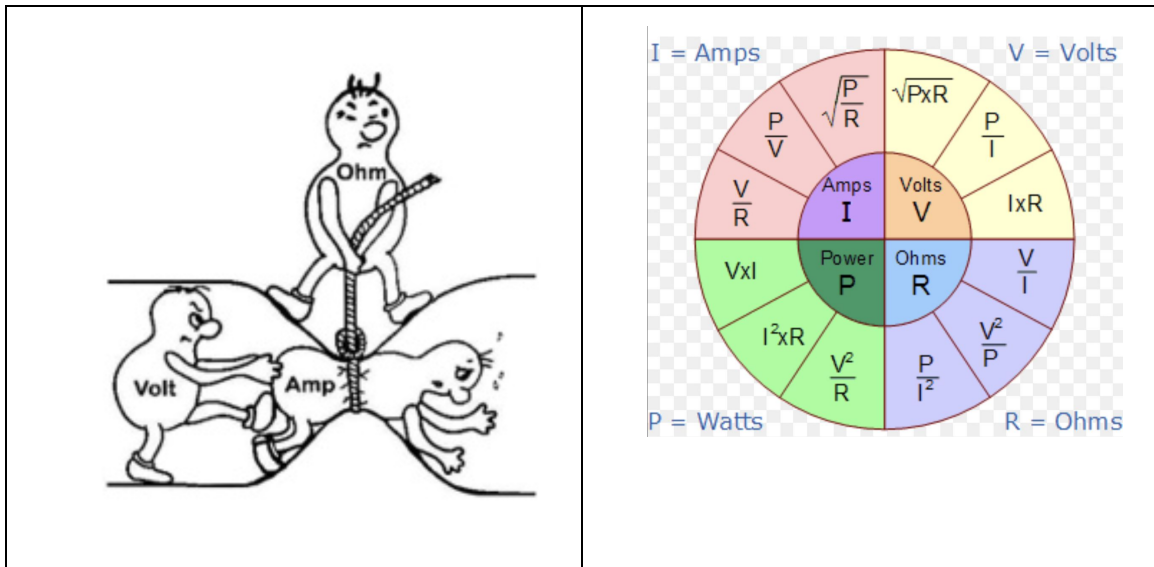

A Basic Kiln Circuit

A kiln includes two separate kinds of circuits that work together. One is the low-voltage control circuit. The other is the high-voltage power circuit. Here are the components (split into the two circuits)

A basic kiln heating and control circuit includes the following components. Each one of these parts must work for the whole system to work.

Heating (Power) Circuit

1. **Power source:** The power source is where the kiln draws its energy from. It can be a standard electrical outlet or a more specialized power source for larger kilns.
2. **Terminal Block:** This is where the external power source connects to the kiln.
3. **Fuses:** Fuses protect the kiln from power surges or other electrical malfunctions by breaking the circuit if too much power flows through it. Fuses may be inside the kiln (on larger kilns) but are also used on the power source (as in a circuit breaker or fuse box).
4. **Contactors:** Contactors are electrical switches that turn the heating elements on and off as directed by the temperature controller. The power is switched by the contacts in the contactors/relays.
5. **Element Terminals:** These are where the element ends connect to the high-temperature power wire.

6. **Heating elements:** The heating elements are responsible for heating the kiln. They are made of a special metal resistance alloy and are designed to withstand high temperatures and produce heat with a specific amount of resistance.

Control Circuit

1. **On/Off Switch:** The on/off switch only turns the power off to the control circuit.
2. **Control Fuse:** After the on/off switch there is a small fuse that will break power to the control circuit if there is a short circuit or too much power is being pulled.
3. **Transformer:** This transforms the high voltage from the power source into low voltage to operate the control and the relays.
4. **Temperature controller:** The temperature controller receives the temperature information from the thermocouple and adjusts the amount of power being supplied to the heating elements to maintain a consistent temperature inside the kiln. There are programs made from **ramps** (rate of temperature increase), **set points** (temperature), and **holds** (duration at the set point in time). Controls can be programmed to go up and also to go down at a programmed rate (as long as the cooling rate is no faster than the heat loss of the kiln).
5. **Thermocouple:** A thermocouple is a temperature sensor that measures the temperature inside the kiln. A thermocouple is made of two slightly different metal alloys. A very low voltage (millivolt) current is produced by the effect of temperature on these dissimilar metals. That current is proportional to the temperature inside the kiln. This millivoltage is transmitted to the temperature control through specially calibrated wires (the **thermocouple connection wires**). There are different kinds of thermocouples (we use Type K and also platinum Type S for super high firing).
6. **Contactors/Relays:** The control has one or more electronic switches that operate the magnetic coil in the relay. In the case of SSR (**Solid State Relays**), the signal from the control is a very fast signal (for the kind we normally use it is switching at 1/60 of a second compared to a typical 25 seconds **cycle time** that we use for mechanical relays).
7. **Wires and Terminals:** All the wires and places where they connect need to be tight and properly sized for the system to work.

How a switch (relay) works

1. A switch is an electrical device that allows you to control the flow of electricity through a circuit. It can be compared to a valve that can be opened or closed to allow or block water flow through a pipe. In the case of a switch, it can be opened or closed to allow or block the flow of electricity through a wire.
2. It consists of a contact, which can be moved to either open or close the circuit.

3. When the switch is closed, the contact touches the two metal terminals, completing the circuit and allowing electricity to flow through (think of a gate).
4. When the switch is open, the contact breaks the circuit, interrupting the flow of electricity.
5. This on/off function of the switch allows you to control the flow of electricity to the elements.

What is a Temperature Control?

1. A temperature control works by monitoring the temperature of the system or environment using a thermocouple (the little probe that sticks into the kiln).
2. If the temperature is too high or too low, the temperature control sends a signal to a control system to take action.
3. The control system can then adjust the temperature by turning on or off relays, contactors, or Solid State Relays (SSRs).

Why use Zone Control?

1. **Improved temperature uniformity:** Zone control can help achieve a more uniform temperature distribution, which is important for ensuring consistent and high-quality results. With zone control there are two or three thermocouples that control the various zones of the kiln.
2. **Energy efficiency:** By controlling the temperature in three zones, the energy required to maintain the desired temperature can be minimized, resulting in lower energy costs.
3. **Longer heating element lifespan:** Precise temperature control can prevent overheating and thermal cycling, which can extend the lifespan of the heating element.

Series Vs Parallel Element Circuits

1. **An electrical circuit is a path that electricity can flow through.** There are two main types of circuits: series and parallel. Element circuits can be in series or parallel depending on the needs of the design of the kiln.
2. In a **series circuit**, the components are **connected in a single path**, so the electricity has to flow through each component one after the other. Think of it like a line of people holding hands - if one person lets go, the line is broken and the electricity can't flow.
3. In a **parallel circuit**, the components are **connected in multiple paths**, so the electricity can flow through each component at the same time. Think of it like a group of people holding hands in a circle - if one person lets go, the circle is still complete and the electricity can still flow through the other paths.

4. The main difference between series and parallel circuits is how they affect the current and voltage. In a series circuit, the current is the same through each component, but the voltage is split between them. This means that if one component has too much resistance, it can affect the whole circuit. In a parallel circuit, the voltage is the same across each component, but the current is split between them. This means that if one component fails, the others can still work.
5. Overall, series circuits are good for when you need to control the current, and parallel circuits are good for when you need redundancy and reliability.

Series wiring on an element circuit:

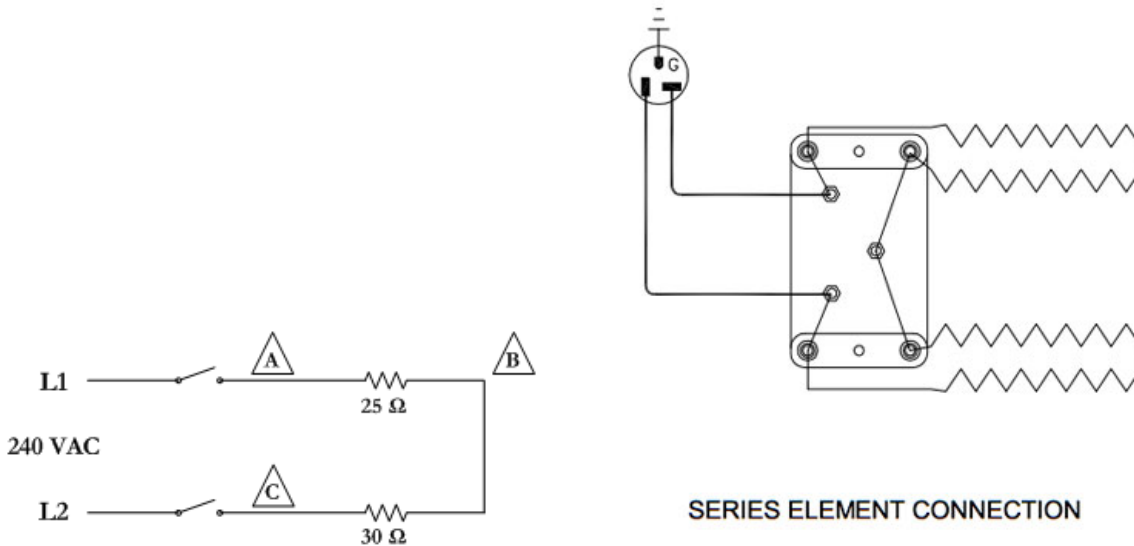

Parallel wiring on an element circuit:

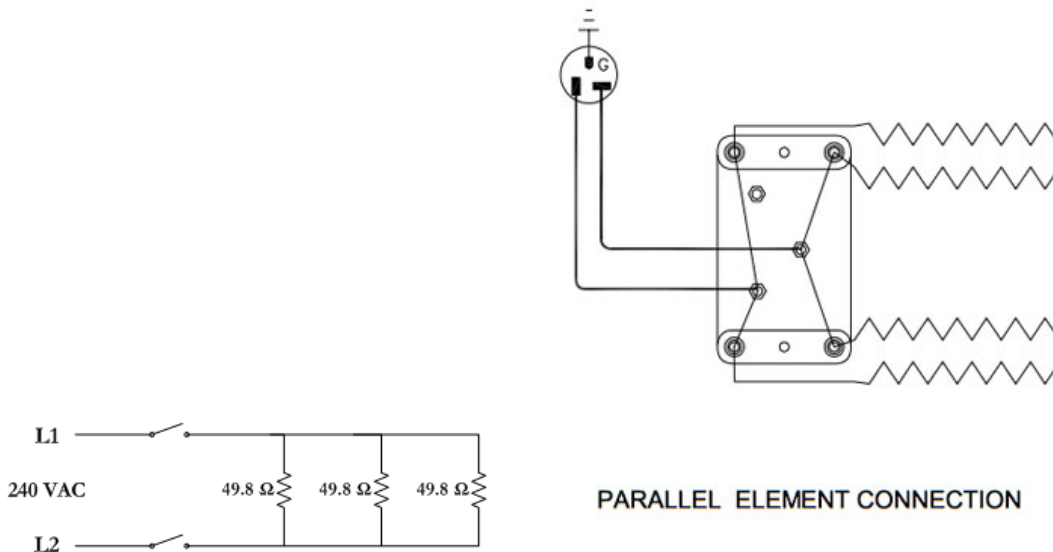

Why do heating elements age?

- Oxidation: Heating elements react with the air and form an oxide layer on the surface. Over time as this layer increases, the element increases in resistance, and less current flows through so that the amount of watts (heat) goes down.
- Physical wear and tear: Heating elements can become damaged or deformed over time due to exposure to high temperatures, expansion, and contraction, or mechanical stress.
- Contamination: If the heating element comes into contact with contaminants, it can become less effective at transferring heat.

What is Single Phase vs Three Phase?

- Electricity is generated as three-phase electric power. It uses three different wires to transmit electricity. Each wire carries an electric current that is out of sync with the other wires, which means that the overall flow of electricity is always constant and steady. This helps to provide a more consistent and efficient supply of power to devices that require a lot of electricity, such as electric motors and large appliances. Three-phase power is commonly used in industrial and commercial settings, but it can also be found in some residential applications (rarely in the USA).
- Typically the power you get in a residential area is single phase. The utility company feeds individual houses with two wires from the three-phase main power line. There is also a Neutral.
- Three-phase power uses three "hot" lines, while single-phase power uses two wires.

Delta vs Wye Three-Phase

- For the three-phase "delta" 208 or 240 volts is measured between any two of the three wires. 120 volts is measured from any hot 240-volt line to Neutral.
- For three-phase "wye" (seen in some industrial installations in the USA and most other countries) 220 to 240 volts is measured from any hot wire and Neutral.

Wire Sizing

- The specification sheets and web pages have "full load amps", fuse size and wire gauges associated with each kiln model. "Full Load Amps" is the the amount of power needed by the kiln expressed in amps when all circuits are firing and the elements are new.
- "Fuse Size" is the fuse or circuit breaker size that is needed to fuse the kiln. This is rated at 125% of the "Full Load Amps" but moves in rounded increments like 60, 70, 80, 90, etc. (note: thi is the USA standard but some countries are different. The extra 25% prevents nuisance tripping)
- "Wire Gauge" is the thickness of the wire that is typically used to connect the kiln to a fused disconnect box. The higher the number the smaller the wire. NOTE: When you are going beyond 15 to 25 feet of hook up wire then you will probably have to increase the wire size. For instance lets say you have an e23T that requires a 6 gauge wire but you have 60 feet from the Circuit Breaker panel to the kiln. The typical way to do this would be to run 4 gauge wire from the Circuit Breaker panel to a small 60 amp fused disconnect switch right near the kiln. Then the wire from that box to the kiln could be the specified 6 gauge.
- THE SIZE OF THE WIRE IS LIKE THE SIZE OF A FUSE. MULTIPLY THE ACTUAL AMPS GOING THROUGH THE WIRE BY 1.25 TO GET THE CAPACITY NEEDED.
- An example is that an e23T-240/1P kiln used 48 full load amps, takes a Number 6 wire to hook it up and requires a 60 amp fuse (Assuming 60 Deg C wire).
- A good website calculator for figuring out the size of wire needed to hook up a kiln is:
<http://wiresizecalculator.net/>

Wire Gauge Size	Copper		
	60°C (140°F) NM-B, UF-B	75°C (167°F) THW, THWN, SE, USE, XHHW	90°C (194°F) THWN-2, THHN, XHHW-2, USE-2
14	15	20	25
12	20	25	30
10	30	35	40
8	40	50	55
6	55	65	75
4	70	85	95
3	85	100	115
2	95	115	130
1	---	130	145
1/0	---	150	170
2/0	---	175	195
3/0	---	200	225
4/0	---	230	260
250	---	255	290
300	---	285	320
350	---	310	350
500	---	380	430
600	---	420	475
750	---	475	585
1000	---	545	615